

Item# _____
Project: _____
Qty: _____

Reach-In Freezer

RF-1-19
One Door Freezer



RF-1*
One Door Freezer



RF-2-35
Two Door Freezer



RF-2*
Two Door Freezer



RF-3(DV)*
Three Door Freezer



Features

- Now with Stainless Steel Interior*
- Electronic Thermostat and Digital LED Temperature Display
- High Efficiency CFC Free Insulation
- Stainless Steel Front and Sides
- Self-Closing Doors with Full Length Handle, Remain Open Past 90°
- 3 Shelves Per Door
- Shipped with Casters Not Installed
- UL Safety and UL Sanitation Approved

You will appreciate the attractive professional aesthetics of these units which will add curb appeal to any type of business. Our units are featured with a heavy duty 304 series stainless steel interior and 304 stainless steel floor, 430 series stainless steel exterior door & front panel, self-closing lockable doors, digital controls with a LED readout and foamed in place polyurethane cell insulation. Unit is shipped with casters not installed (2 Brake and 2 Non Brake).

The single door includes 3 epoxy coated wire shelves, the double door includes 6 epoxy coated wire shelves and the triple door includes 9 epoxy coated wire shelves, all with adjustable mounting brackets for greater flexibility.

The bottom mounted compressor designed to hold temperatures between -10° F and 0° F.

Conforms to UL471, CSA C22.2 and NSF 7 Standards.

Two Year - Parts & Labor on entire unit. Valid in United States
Three Year - Additional Compressor, Part Only



Serv-Ware
www.servware.com

Phone:(800).768.5953

Revised 4/19

Fax:(800).976.1299



Serv-Ware

Reach-In Freezer

RF-1-19 One Door

Exterior Dimensions 26.8" W x 25.6" D x 82.3" H
 Net Volume 19 cu. ft.
 Shipping Weight 291 lbs.
 Exterior Material 430 Stainless Steel
 Interior Material Painted Aluminum
 304 S/S Floor
 Insulation Material CFC Free Foam
 Shelf Material Epoxy Coated Foam
 Temperature -10°F – 0°F
 Refrigerant R404A
 Defrosting Every 6 Hours
 H/P 5/8
 Voltage / Hz / Phase 115 / 60 / 1
 Amps 11
 Nema Plug 5-15P

RF-1 One Door

Exterior Dimensions 27" W x 33" D x 82.7" H
 Net Volume 23 cu. ft.
 Shipping Weight 320 lbs.
 Exterior Material 430 Stainless Steel
 Interior Material Stainless Steel
 202 S/S Floor
 Insulation Material CFC Free Foam
 Shelf Material Epoxy Coated Foam
 Temperature -10°F – 0°F
 Refrigerant R404A
 Defrosting Every 6 Hours
 H/P 5/8
 Voltage / Hz / Phase 115 / 60 / 1
 Amps 11
 Nema Plug 5-15P

RF-2-35 Two Door

Exterior Dimensions 39.5" W x 32.7" D x 82.3" H
 Net Volume 35 cu. ft.
 Shipping Weight 441 lbs.
 Exterior Material 430 Stainless Steel
 Interior Material Painted Aluminum
 304 S/S Floor
 Insulation Material CFC Free Foam
 Shelf Material Epoxy Coated Foam
 Temperature -10°F – 0°F
 Refrigerant R404A
 Defrosting Every 6 Hours
 H/P 1
 Voltage / Hz / Phase 115 / 60 / 1
 Amps 12
 Nema Plug 5-15P

RF-2 Two Door

Exterior Dimensions 54" W x 33" D x 82.3" H
 Net Volume 49 cu. ft.
 Shipping Weight 488 lbs.
 Exterior Material 430 Stainless Steel
 Interior Material Stainless Steel
 202 S/S Floor
 Insulation Material CFC Free Foam
 Shelf Material Epoxy Coated Foam
 Temperature -10°F – 0°F
 Refrigerant R404A
 Defrosting Every 6 Hours
 H/P 1
 Voltage / Hz / Phase 115 / 60 / 1
 Amps 12
 Nema Plug 5-15P

RF-3 Three Door

Exterior Dimensions 81" W x 33" D x 82.3" H
 Net Volume 72 cu. ft.
 Shipping Weight 706 lbs.
 Exterior Material 430 Stainless Steel
 Interior Material Stainless Steel
 202 S/S Floor
 Insulation Material CFC Free Foam
 Shelf Material Epoxy Coated Foam
 Temperature -10°F – 0°F
 Refrigerant R404A
 Defrosting Every 6 Hours
 H/P 1-1/4
 Voltage / Hz / Phase 230 / 60 / 1
 Amps 16
 Nema Plug L14-20 P

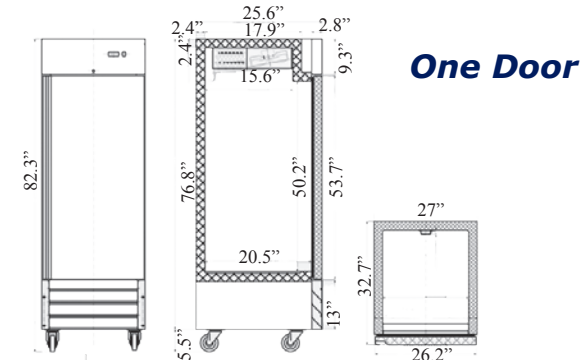

One Door

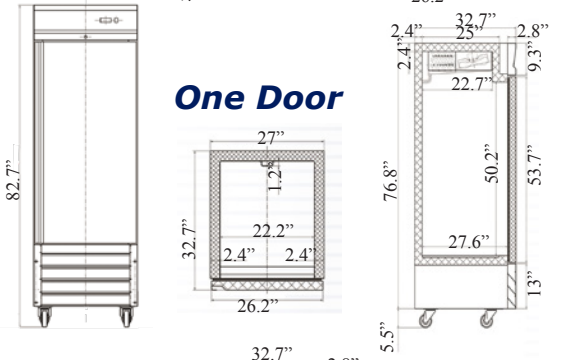

One Door

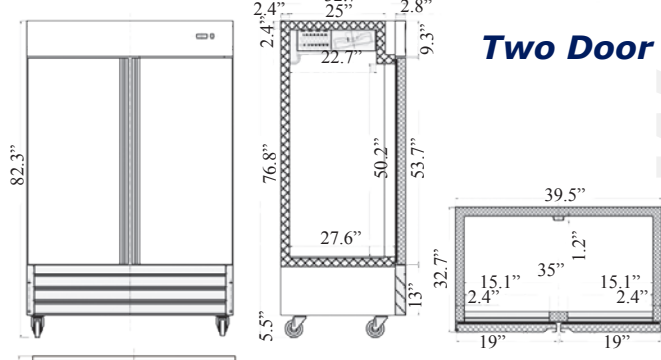

Two Door

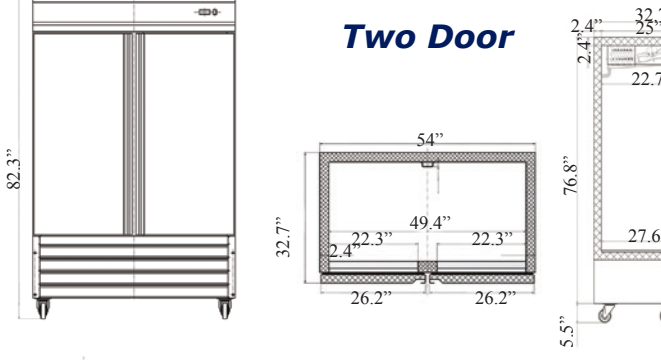

Two Door

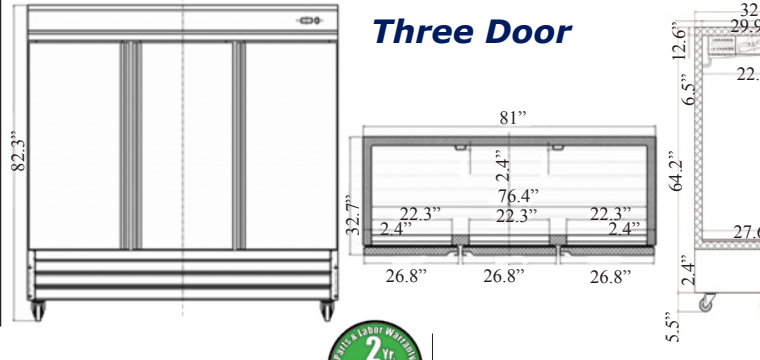

Three Door



Serv-Ware
www.servware.com

Phone: (800).768.5953

Revised 4/19

Fax: (800).976.1299

